

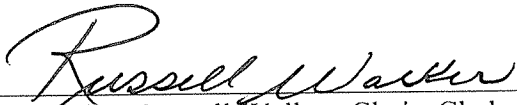

PO Box 1749
Halifax, Nova Scotia
B3J 3A5, Canada

Item No. 9.2
Halifax Regional Council
March 23, 2010
April 20, 2010

TO: Mayor Kelly and Members of Halifax Regional Council

SUBMITTED BY: 
Councillor Russell Walker, Chair, Chebucto Community Council

DATE: March 3, 2010

SUBJECT: Case 01205: MPS and LUB Amendment for a Development Agreement -
50 Bedford Highway, Halifax

ORIGIN

March 1, 2010 meeting of Chebucto Community Council.

RECOMMENDATION

It is recommended that Halifax Regional Council:

1. Give First Reading to the proposed amendments to the Halifax Municipal Planning Strategy and the Halifax Mainland Land Use By-law contained in Attachment A of the report dated February 4, 2010 and schedule a joint public hearing with Chebucto Community Council.
2. Approve the amendments to the Halifax Municipal Planning Strategy and the Halifax Mainland Land Use By-law as contained in Attachment A of the report dated February 4, 2010.

BACKGROUND/DISCUSSION

At their March 1, 2010 meeting Chebucto Community Council moved Notice of Motion to consider approval of the proposed Development Agreement contained in Attachment B of the report dated February 4, 2010 to allow for a mixed use building, and schedule a joint public hearing with Regional Council.

BUDGET IMPLICATIONS

None associated with this report.

FINANCIAL MANAGEMENT POLICIES/BUSINESS PLAN

This report complies with the Municipality's Multi-Year Financial Strategy, the approved Operating, Capital and Reserve budgets, policies and procedures regarding withdrawals from the utilization of Capital and Operating reserves, as well as any relevant legislation.

ALTERNATIVES

None.

ATTACHMENTS

Attachment A: Staff report dated February 4, 2010 - Case 01205: MPS and LUB Amendment for a Development Agreement - 50 Bedford Highway, Halifax

A copy of this report can be obtained online at <http://www.halifax.ca/council/agendasc/cagenda.html> then choose the appropriate meeting date, or by contacting the Office of the Municipal Clerk at 490-4210, or Fax 490-4208.

Report Prepared by: Shawnee Gregory, Legislative Assistant, 490-6521

ATTACHMENT A



PO Box 1749
Halifax, Nova Scotia
B3J 3A5 Canada

Chebucto Community Council
March 1, 2010

TO: Chair and Members of Chebucto Community Council

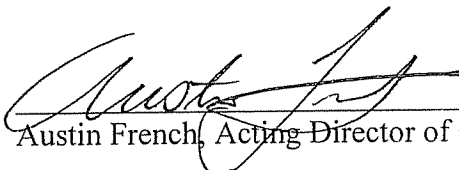
SUBMITTED BY: 
Austin French, Acting Director of Community Development

DATE: February 4, 2010

SUBJECT: **Case 01205: MPS and LUB Amendment for a Development Agreement - 50 Bedford Highway, Halifax**

ORIGIN

- Application by Basin Vista Developments Limited.
- Regional Council initiated the plan amendment process on February 3, 2009.

RECOMMENDATION

It is recommended that Chebucto Community Council:

1. Move Notice of Motion to consider approval of the proposed Development Agreement contained in Attachment B to allow for a mixed use building, and schedule a joint public hearing with Regional Council.
2. Recommend that Regional Council give First Reading to the proposed amendments to the Halifax Municipal Planning Strategy and the Halifax Mainland Land Use By-law contained in Attachment A and schedule a joint public hearing with Chebucto Community Council.
3. Recommend that Regional Council approve the amendments to the Halifax Municipal Planning Strategy and the Halifax Mainland Land Use By-law as contained in Attachment A.

BACKGROUND:

Location and Land Uses: The property, currently occupied by the Basin View Motel, is located on the west side of the Bedford Highway, just off the Halifax Peninsula (Refer to Map1). It is surrounded by commercial uses, a mixture of housing types, including detached dwellings, low and high-rise multiple unit residential buildings, and across Bedford Highway the railway tracks, the Bedford Basin and Fairview Cove Container Terminal with its associated harbour-related industrial uses to the south.

Designation and Zoning: The property is within the Highway Commercial Designation and Highway Commercial (C-2B) Zone, which allows for a variety of commercial uses with an emphasis upon activities that generally benefit from a location upon a highway and residential uses, including apartment buildings to a maximum height of 35 feet.

Synopsis of the Proposed Development: The proposal is for a signature mixed use building. The hotel/office portion will be four and three stories and the twenty storey residential tower will extend above the landscaped podium which tops the third level. The whole building will contain 155 two bedroom residential units and 7,246.2 m² (78,000 ft²) gross floor area of hotel or office space including a range of associated uses. Both building height and density have been capped. The building is designed to have two entrances which keep the two uses separated. The proposed mixed use building with its landscaped terrace amenity area works with site topography to place required parking indoors.

Approval Process: The approval process for this application has two steps:

1. Regional Council can consider and if deemed appropriate, adopt the proposed amendments to the MPS and LUB; and
2. Provided that Regional Council approves the amendments, Chebucto Community Council can consider the development agreement for 50 Bedford Highway.

A joint public hearing can be held between Regional Council and Chebucto Community Council to consider both the amendments and the development agreement. However, only Chebucto Community Council can render a decision on the development agreement, and only following the approval of the MPS and LUB amendments by Regional Council and the Province.

A decision by Council on an MPS amendment cannot be appealed, however, an appeal mechanism to the Nova Scotia Utility and Review Board does exist for a refusal of the development agreement by Community Council.

DISCUSSION:

Site specific MPS amendments and policy changes should generally only be considered where circumstances related to policies of the MPS have changed significantly. In this situation the existing use is being re-created in a new form and intensified by the addition of the residential component. An alternative use, office, is being allowed to provide adaptability. Considering an MPS amendment to allow a development agreement for this mixed use seems appropriate to ensure that the siting and

design of the building takes into consideration the surrounding uses and provides an opportunity for improving access for vehicles to this and abutting sites.

The MPS policy allows a mixed use building but sets out a variety of factors that are to be considered. These include servicing capacity, architectural design, safe vehicular access, parking, amenities, landscaping, lighting, signage, archaeological monitoring and separation of uses. All of these factors have been considered in the Development Agreement.

The Development Agreement:

- includes sections dealing with the building architecture, site design, landscaping, parking, circulation and access, services, maintenance, signs and archaeological monitoring;
- has an emphasis on high quality materials and the exterior building materials which are proposed to be glass curtain wall, decorative precast concrete and composite metal panels (see Schedules C, D, E and F of Attachment B);
- allows some flexibility in residential unit mix while a maximum density has been identified;
- addresses concerns related to lighting of the building and the site as well as signage;
- requires mechanical equipment to be screened;
- requires exposed foundation/garage walls to be finished;
- ensures ample vehicular parking is provided for both the residential and hotel/office uses;
- allows 3 levels of enclosed parking containing 243 spaces and 30 surface spaces;
- requires 68 bicycle parking spaces inside and 20 bicycle parking spaces outside the building;
- requires as a minimum the landscape shown on the Landscape Concept Plan which is attached to the development agreement as Schedule G of Attachment B;
- provides requirements for protection of the non-disturbance area;
- ensures the landscaped podium is accessible for both the hotel/office and the residential uses;
- provides for a walking path through the non-disturbance area at the rear of the property;
- requires internal amenity space; and
- requires the Developer to comply with Provincial archaeological monitoring requirements;
- requires that the site be adequately serviced.

Site Access: The existing condition of multiple individual driveways will be improved by the installation of a single, new access driveway shared with the adjacent automobile dealerships. This driveway will be controlled by semi-actuated traffic lights triggered by left turning vehicles. A left hand turn lane is included to improve access and flow on the Bedford Highway. The driveway intersection and traffic lights will be installed by the Developer.

By-law Conformance: The building generally meets the R-4 (Multiple Dwelling) Zone requirements as identified in Attachment C. Clause 2.3.1 of the development agreement does give relief from some sections of the By-law which deal with restrictions on commercial uses and signage. These items have been addressed within the development agreement.

Height: Although the Bedford Highway has a height restriction of 35 feet, this property has unique features which mitigate some of the impact of the proposed height. The general area is understood to be a former quarry. The proposed building is within this area. The residential uses surrounding the property are on the outer upper edge of the pit, at a much higher elevation. There are trees to be preserved abutting the residential uses to the rear. This substantial change in grade across the site serves to reduce the impact of the building to the residences located at the higher level.

Private Views: Concerns have been voiced about the impact of this building on private views for abutting properties. Private views are not protected. Regardless, the Developer has designed a residential tower which, given its shape, has provided maximum opportunities for viewing around the tower. This, along with the grade change, attempt to mitigate the impact to private views.

Public Consultation: Minutes are attached for the public information meeting held on April 2, 2009, (Attachment D). The area of notification, should a public hearing be held, is shown on Map 1.

Legal Review: Consistent with Chebucto Community Council's motion of October 5, 2009, the proposed development agreement has been reviewed by HRM's Legal department and the content of the agreement has been approved.

BUDGET IMPLICATIONS

There are no budget implications. The Developer will be responsible for all costs, expenses, liabilities and obligations imposed under or incurred in order to satisfy the terms of this Agreement. The administration of the agreement can be carried out within the approved budget with existing resources.

FINANCIAL MANAGEMENT POLICIES/BUSINESS PLAN

This report complies with the Municipality's Multi-Year Financial Strategy, the approved Operating, Capital and Reserve budgets, policies and procedures regarding withdrawals from the utilization of Capital and Operating reserves, as well as any relevant legislation.

ALTERNATIVES

1. Halifax Regional Council may choose to approve the requested amendments to the Municipal Planning Strategy and Mainland Land Use By-law.
2. Halifax Regional Council may choose to refuse the requested amendments to the MPS and Mainland LUB. Regional Council is under no obligation to consider a request to amend its MPS and a decision not to amend the MPS cannot be appealed.

ATTACHMENTS

Map 1	Location and Zoning
Attachment A	Amendments to the Halifax MPS and Halifax Mainland LUB
Attachment B	Development Agreement with Schedules
Attachment C	By-law Conformance Chart (drawing number 01205-0057)
Attachment D	Public Information Meeting Minutes April 2, 2009

A copy of this report can be obtained online at <http://www.halifax.ca/commcoun/cc.html> then choose the appropriate Community Council and meeting date, or by contacting the Office of the Municipal Clerk at 490-4210, or Fax 490-4208.

Report Prepared by: Randa Wheaton, Senior Planner, Community Development, 490-4499

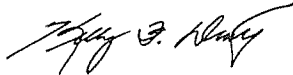

Report Approved by: _____
Kelly Denty, Acting Manager, Planning Services, 490-6011

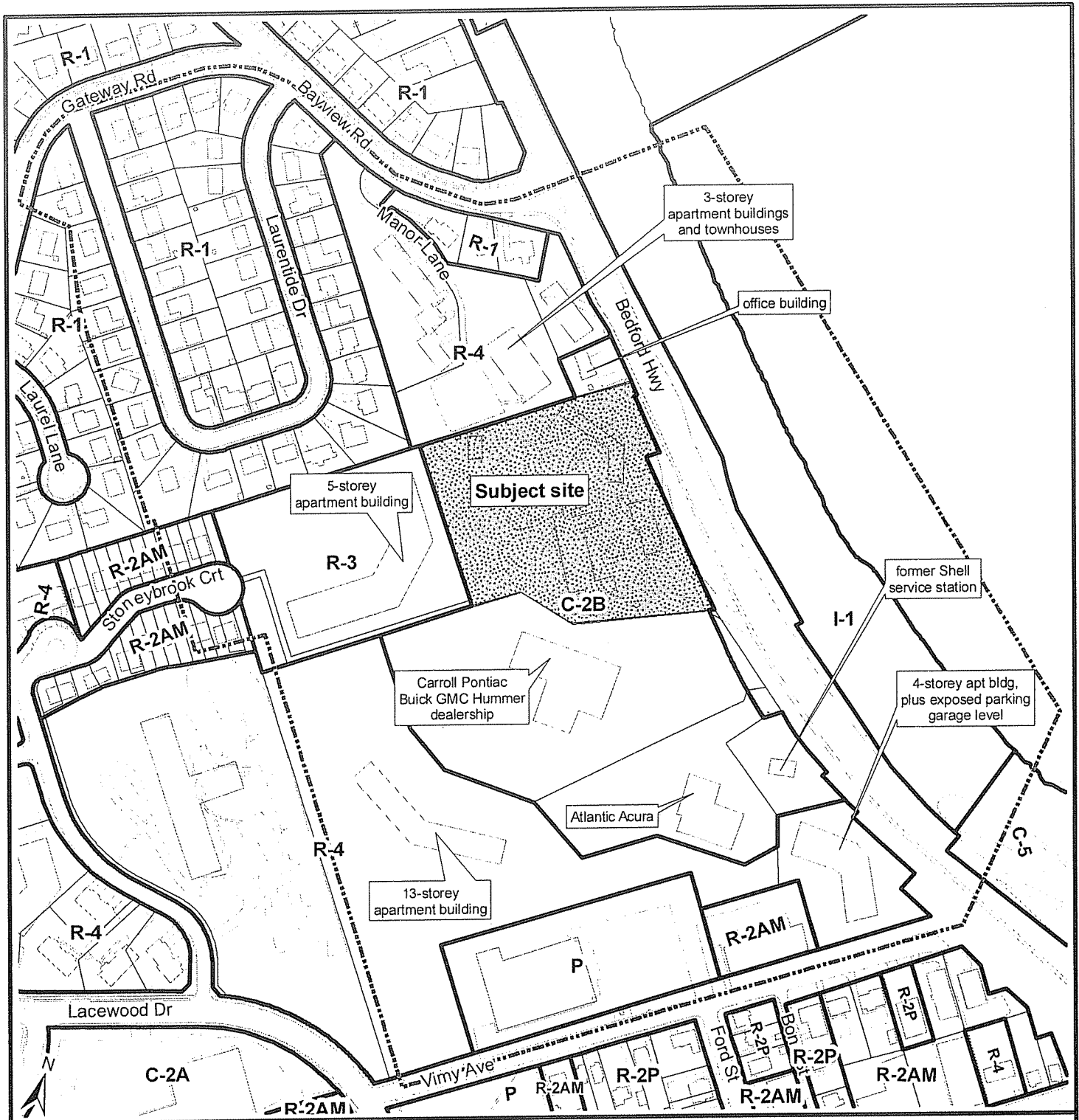

Map 1 - Location and Zoning

50 Bedford Highway
Halifax

 Subject area

Halifax Mainland
Land Use By-Law Area

Zone

- R-1 Single Family Dwelling
- R-2 Two Family Dwelling
- R-2P General Residential
- R-2AM General Residential Conversion
- R-3 Low-Rise Apartment
- R-4 Multiple Dwelling
- C-2A Minor Commercial
- C-2B Highway Commercial
- I-1 General Industrial
- P Park and Institutional

HALIFAX
REGIONAL MUNICIPALITY
COMMUNITY DEVELOPMENT
PLANNING SERVICES

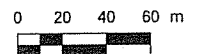

This map is an unofficial reproduction of a portion of the Zoning Map for the Halifax Mainland Land Use By-Law Area.

HRM does not guarantee the accuracy of any representation on this plan

ATTACHMENT A

Proposed Amendments to the Halifax Municipal Planning Strategy

BE IT ENACTED by the Council of the Halifax Regional Municipality that the Municipal Planning Strategy for Halifax is hereby amended as follows:

Add Policies 1.7 and 1.7.1 to Section VIII (Bedford Highway Secondary Planning Strategy, Residential Environments) of the Halifax Municipal Planning Strategy immediately after 1.6 (iv) to read as follows:

- 1.7 For the property at 50 Bedford Highway (PID # 00296665) the Municipality may permit the development of a mixed use building by development agreement.**
- 1.7.1 Any development permitted pursuant to Policy 1.7 shall be compatible with the surrounding area and this shall be achieved by attention to a variety of factors for which conditions may be set out in the development agreement, such as but not limited to:**
- (a) the adequacy of the servicing capacity of the site;**
 - (b) the architectural design of the building including building materials;**
 - (c) provision and improvement of safe vehicular access and egress;**
 - (d) the adequacy of vehicular and bicycle parking facilities;**
 - (e) the provision of useable open space and recreational amenities;**
 - (f) adequate site landscaping and protection of non-disturbance areas;**
 - (g) appropriate lighting and signage;**
 - (h) archaeological monitoring and protection; and**
 - (i) appropriate separation of residential and commercial uses.**

THIS IS TO CERTIFY that the by-law of which this is a true copy was duly passed at a duly called meeting of the Council of Halifax Regional Municipality held on the _____ day of _____, 2010.

Given under the hand of the Municipal Clerk and under the corporate seal of the Municipality this _____ day of _____, 2010.

Municipal Clerk

Proposed Amendments to the Halifax Mainland Land Use By-law

BE IT ENACTED by the Council of the Halifax Regional Municipality that the Land Use Bylaw for Halifax Mainland is hereby amended as follows:

Add Section 71(10) to the Halifax Mainland Land Use By-law immediately after 71(9) to read as follows:

71(10) **50 Bedford Highway**

Council may, by development agreement, pursuant to Policies 1.7 and 1.7.1 of Section VIII of the Halifax Municipal Planning Strategy, permit the development of a mixed use building at 50 Bedford Highway, Halifax (PID #00296665).

THIS IS TO CERTIFY that the by-law of which this is a true copy was duly passed at a duly called meeting of the Council of Halifax Regional Municipality held on the _____ day of _____, 2010.

Given under the hand of the Municipal Clerk and under the corporate seal of the Municipality this _____ day of _____, 2010.

Municipal Clerk

ATTACHMENT B

THIS AGREEMENT made this day of , 2010,

BETWEEN:

BASIN VISTA DEVELOPMENTS LIMITED

a body corporate, in the Halifax Regional Municipality,
Province of Nova Scotia, (hereinafter called the "Developer")

OF THE FIRST PART

-and-

HALIFAX REGIONAL MUNICIPALITY

a municipal body corporate, Province of Nova Scotia
(hereinafter called the "Municipality")

OF THE SECOND PART

WHEREAS the Developer is the registered owner of certain lands located on the Bedford Highway, Halifax (PID # 00296665) and which said lands are more particularly described in Schedule A hereto (hereinafter called the "Lands");

AND WHEREAS, the Developer has requested that the Municipality enter into a Development Agreement to allow for the construction of a mixed use building on the Lands pursuant to the provisions of the *Halifax Regional Municipality Charter* and pursuant to Policies 1.7 and 1.7.1 of the Halifax Municipal Planning Strategy and Section 71(10) of the Halifax Mainland Land Use By-law;

AND WHEREAS the Chebucto Community Council of Halifax Regional Municipality approved this request at a meeting held on 2010, referenced as Municipal Case Number 01205;

THEREFORE in consideration of the benefits accrued to each party from the covenants herein contained, the Parties agree as follows:

PART 1: GENERAL REQUIREMENTS AND ADMINISTRATION

1.1 Applicability of Agreement

The Developer agrees that the Lands shall be developed and used only in accordance with and subject to the terms and conditions of this Agreement.

1.2 Applicability of Land Use By-law and Subdivision By-law

Except as otherwise provided for herein, the development, subdivision and use of the Lands shall comply with the requirements of the Halifax Mainland Land Use By-law and the Subdivision By-law, as may be amended from time to time.

1.3 Applicability of Other By-laws, Statutes and Regulations

1.3.1 Further to Section 1.2, nothing in this Agreement shall exempt or be taken to exempt the Developer, lot owner or any other person from complying with the requirements of any by-law of the Municipality applicable to the Lands (other than the Land Use By-law to the extent varied by this Agreement), or any statute or regulation of the Provincial/Federal Government and the Developer or Owner agrees to observe and comply with all such laws, by-laws and regulations in connection with the development and use of the Lands.

1.3.2 The Developer shall be responsible for securing all applicable approvals associated with the on-site and off-site servicing systems required to accommodate the development, including but not limited to sanitary sewer system, water supply system, stormwater sewer and drainage system, and utilities. Such approvals shall be obtained in accordance with all applicable by-laws, standards, policies, and regulations of the Municipality and other approval agencies. All costs associated with the supply and installation of all servicing systems and utilities shall be the responsibility of the Developer. All design drawings and information shall be certified by a Professional Engineer or appropriate professional as required by this Agreement or other approval agencies.

1.4 Conflict

1.4.1 Where the provisions of this Agreement conflict with those of any by-law of the Municipality applicable to the Lands (other than the Land Use By-law to the extent varied by this Agreement) or any provincial or federal statute or regulation, the higher or more stringent requirements shall prevail.

1.4.2 Where the written text of this agreement conflicts with information provided in the Schedules attached to this agreement, the written text of this agreement shall prevail.

1.4.3 Where metric values conflict with imperial values within the written text of this Agreement, the metric values shall prevail.

1.5 Costs, Expenses, Liabilities and Obligations

The Developer shall be responsible for all costs, expenses, liabilities and obligations imposed under

or incurred in order to satisfy the terms of this Agreement and all Federal, Provincial and Municipal laws, by-laws, regulations or codes applicable to the Lands.

1.6 Provisions Severable

The provisions of this Agreement are severable from one another and the invalidity or unenforceability of one provision shall not affect the validity or enforceability of any other provision.

PART 2: USE OF LANDS AND DEVELOPMENT PROVISIONS

2.1 Schedules

The Developer shall develop the Lands, in a manner, which, in the opinion of the Municipality's Development Officer, conforms with Schedules B to G inclusive attached to this agreement numbered as 01205-0050 and 01205-0052 to 01205-0056 inclusive. The Schedules to this Agreement are:

Schedule A	Legal Description for 50 Bedford Highway, Halifax
Schedule B	Site Plan numbered 01205-0056
Schedule C	East Elevation numbered 01205-0052
Schedule D	West Elevation numbered 01205-0053
Schedule E	North Elevation numbered 01205-0054
Schedule F	South Elevation numbered 01205-0055
Schedule G	Landscape Concept Plan numbered 01205-0050

2.2 General Description of Land Use

The uses of the Lands permitted by this Agreement, subject to its terms and as illustrated on the Schedules attached hereto, are as follows:

- (a) 155 two bedroom residential dwelling units;
- (b) a maximum of 7,246.2 square metres (78,000 square feet) gross floor area of hotel or office space;
- (c) private open space, landscape areas, signage and walkways;
- (d) vehicular parking, loading and circulation areas;
- (e) uses accessory to the foregoing, including, but not limited to, a restaurant and lounge, fitness center, banquet facility, spa/hair salon, day care facility, gift shop and service commercial uses; and
- (f) temporary accessory uses to the foregoing, including a sales office and construction trailer.

2.3 Detailed Provisions for Land Use

- 2.3.1 The building must comply with the R-4 Multiple Dwelling Zone requirements for Mainland Halifax with the exception of Sections 29(1)(f) (one office), 29A (commercial uses), 29B (signs), 30 (no window display) and 32(1) (billboards) and 32(2) (non-illuminated sign).
- 2.3.2 The maximum height of the building shall not exceed 76.2 metres (250 feet) above average grade.
- 2.3.3 The density is to be calculated by the theoretical population generated on the basis of: 1.0 person per bachelor/studio unit; 2.0 persons per one bedroom unit; 2.25 persons per all other apartment types.
- 2.3.4 Further to Section 2.3.3, for the purposes of determining permissible density, one bedroom plus den units shall be considered to be one-bedroom units and two bedroom plus den units shall be considered to be two bedroom units.
- 2.3.5 The residential unit mix may be changed provided that the proposed residential density does not exceed the project residential density of 348.75 persons.
- 2.3.6 A restaurant and lounge shall be permitted provided that:
- a) The seating capacity of the restaurant shall not exceed 60 people;
 - b) The licensed capacity of the lounge shall not exceed 20 people; and
 - c) There is no drive-through window, although room service and take-out may be provided.

2.4 Building Architecture and Site Design

- 2.4.1 Exterior building materials shall mainly consist of decorative precast concrete, glass/curtain wall, Exterior Insulation Finishing System (E.I.F.S.) and composite metal panels. No exposed treated lumber, plain concrete block or vinyl siding shall be used in the construction of the building.
- 2.4.2 All roof mounted mechanical systems (HVAC, cooking exhaust fans, etc.) and/or telecommunication equipment shall be visually integrated into the roof design or screened and shall not be visible from any public street or adjacent residential development. Any mechanical or utility equipment located at grade shall be screened from view from any public street with landscaping or a combination of fencing and landscaping elements.
- 2.4.3 All vents, down spouts, flashing, electrical conduits, utility meters, service connections, and other functional elements shall be treated as integral parts of the design.
- 2.4.4 Lighting shall be directed downward to driveways, parking areas, loading areas, building entrances and walkways and shall be arranged so as to divert the light away from the sky,

- streets, adjacent lots and buildings. The path through the non-disturbance area shall not be lit as this would not align with CPTED (Crime Prevention through Environmental Design) principles.
- 2.4.5 All balconies and railings on the building shall be made of decorative metal and glass. Wooden railings are not permitted on the building.
- 2.4.6 Architectural treatment and materials shall be continued around all sides of all buildings.
- 2.4.7 The building shall have a minimum of 68 interior bicycle parking spaces provided within the three levels of underground parking and a minimum of 20 outdoor bicycle parking spaces.
- 2.4.8 The main entrances to both the hotel/office use and the residential portion of the building shall be emphasized by detailing, changes in materials, and other architectural devices such as but not limited to lintels, pediments, pilasters, columns, porticos, overhangs, corner boards, fascia boards or an acceptable equivalent approved by the Municipality's Development Officer. At least one main door shall face the Bedford Highway. Service/delivery entrances shall be integrated into the design of the building and shall not be a dominant feature.
- 2.4.9 Large blank or unadorned walls shall not be permitted. The scale of large walls shall be tempered by the introduction of artwork (murals), green walls, textural plantings and trellises, and architectural detail to create shadow lines (implied windows, cornice lines, offsets in the vertical plane, etc.).
- 2.4.10 Fixed or retractable awnings are permitted at ground floor levels provided the awnings are designed as an integral part of the building façade.
- 2.4.11 Any exposed foundation or parking garage face in excess of 1 metre (3 feet) in height shall be architecturally detailed, veneered with stone or brick, stucco, painted, or treated in an equivalent manner acceptable to the Municipality's Development Officer.
- 2.4.12 Amenity space shall be set aside for private recreational purposes such as common recreational areas, play areas, recreational rooms, roof decks, swimming pools and tennis courts. Amenity space shall include all interior and exterior areas set aside for the exclusive purposes of visual improvement or recreation and shall include areas of landscaping, exercise rooms, community/party rooms, balconies, landscaped podiums and sundecks. The amenity spaces shall be of a size large enough to accommodate the activity for which they are programed to be used. The residential tower is to include a minimum of 1000 square feet of indoor amenity area unless, as an alternative, the tower residents have unlimited access to the hotel amenities.

- 2.4.13 All at grade patios or patios on the roof terrace shall be made of a decorative hard surface with vine covered painted or stained wooden arbors or hedging.
- 2.4.14 A temporary structure shall be permitted on the Lands for the purpose of housing equipment, materials and office related matters relating to the construction and sale of the development in accordance with this Agreement. The structure shall be removed from the Lands prior to the issuance of the last Occupancy Permit.
- 2.4.15 Walkways shall be designed to be barrier free where possible.

2.5 Parking, Circulation and Access

- 2.5.1 The internal driveway layout and the number and layout of parking spaces on the Lands shall be as generally illustrated on Schedules B and G. The parking areas shall maintain a minimum setback from all property lines of 0.6 metres/2 feet and as generally shown on the plans. All parking areas, driveways and circulation aisles shall have a finished hard surface such as asphalt, concrete, paving blocks, interlocking paving stones or an acceptable equivalent in the opinion of the Municipality's Development Officer and shall be defined by concrete curbing. Curbing shall not be asphalt.
- 2.5.2 The parking areas, driveways and circulation aisles shall comply with the requirements of the Land Use By-law for Mainland Halifax as amended from time to time, Bylaw S-300 Respecting Streets, the Municipal Service Systems Guidelines and any other applicable legislation.
- 2.5.3 The building shall have a minimum of 235 interior parking spaces provided within the underground parking levels, to be shared by all uses, and a minimum of 30 outdoor parking spaces to be shared by all uses.

2.6 Landscaping

- 2.6.1 Landscaping for the building shall be provided as a minimum in accordance with the planting plans attached to this agreement as Schedule G. The Developer may provide enhanced landscape features at their own discretion.
- 2.6.2 All plant material shall conform to the Canadian Nursery Trades Association Metric Guide Specifications and Standards, as amended, and sodded areas to the Canadian Nursery Sod Growers' Specifications, as amended. All disturbed areas shall be reinstated to original condition or better.

- 2.6.3 A mixture of native trees and shrubs shall be utilized to reinstate the locations where the existing access driveways are to be removed.
- 2.6.4 The pedestrian walkways, path, walking/service trail, service lane and exterior bicycle parking areas shall be located as shown on Schedules B and G, constructed of concrete in accordance with the applicable HRM specifications unless otherwise specified in the schedules. Bike racks, benches, garbage receptacles and retaining walls shall be provided as specified on the landscape plan, Schedule G or equivalent.
- 2.6.5 Non-disturbance areas as shown on Schedule G shall be preserved and maintained in their natural state. No structures shall be permitted, no excavation, infilling, tree, stump and other vegetation removal or any alteration of any kind shall be permitted in relation to a development. Within the non-disturbance areas as shown on the landscape plan, no living trees shall be cut unless identified as hazardous by a tree care professional. No understory plants, groundcovers or shrubs shall be removed unless identified by a Landscape Architect, Horticulturist or Botanist as an invasive species. In locations where tree preservation has not been possible as identified in this agreement, the Developer is to plant a mix of new native vegetation. Deciduous trees are to be a minimum of 50 mm caliper, coniferous trees are to be a minimum of 1 metre in height and shrubs are to be a minimum of 50 cm high.
- 2.6.6 Notwithstanding Section 2.6.5, the proposed path within the non-disturbance area shall be laid out by the Landscape Architect so as to minimize the impact on the existing vegetation. Every effort shall be made during construction of the path to keep damage to the existing vegetation to a minimum. Reinstatement of damaged areas associated with the path shall be undertaken with compatible native vegetation.
- 2.6.7 Prior to issuance of an Occupancy Permit, the Developer shall submit to the Development Officer a letter prepared by a member in good standing of the Canadian Society of Landscape Architects certifying that all landscaping has been completed according to the terms of this Development Agreement.
- 2.6.8 Notwithstanding the above, the Occupancy Permit may be issued provided that the weather and time of year does not allow the completion of the outstanding landscape works and that the Developer supplies a security deposit in the amount of 110 per cent of the estimated cost to complete the landscaping. The cost estimate is to be provided by a member in good standing of the Canadian Society of Landscape Architects. The security shall be in favour of the Municipality and shall be in the form of a certified cheque or automatically renewing, irrevocable letter of credit issued by a chartered bank. The security shall be returned to the Developer only upon completion of the work as described herein and illustrated on the Schedules, and as approved by the Development Officer.

Should the Developer not complete the landscaping within twelve months of issuance of the occupancy permit, the Municipality may use the deposit to complete the landscaping as set out in Schedule G. The Developer shall be responsible for all costs in this regard exceeding the deposit. Any unused portion of the security deposit shall be returned to the Developer upon completion of the work and its certification.

- 2.6.9 It is the responsibility of the Developer to ensure that the underground parking structures or other structures are capable of supporting loads from all landscaping as well as the anticipated mature weight of the plant material on any rooftop and podium.
- 2.6.10 A minimum of 15 cm (6 inches) of drainage gravel over the extent of the landscape podium plus an additional 40 cm (16 inches) of topsoil for sod; 60 cm (2 ft.) of topsoil for shrubs; and 90 cm (3 ft.) of topsoil for trees, or an equivalent system proposed by a Landscape Architect, shall be provided.
- 2.6.11 Planting on rooftops and podiums above structures shall be carefully selected for their ability to survive in rooftop environments. Rooftop trees shall be located in berms, raised planting beds or containers. Minimum planted sizes shall be as follows:
- (a) deciduous trees: 45 mm caliper (1.8 inch diameter);
 - (b) coniferous trees: 1.5 m (5 ft.) high;
 - (c) shrubs: 2 gallon pot.

2.7 Maintenance

The Developer, while owner of the Lands, and all future property owners shall maintain and keep in good repair all portions of the development on the Lands, including but not limited to, the exterior of the building, fencing, walkways, recreational amenities, parking areas, driveways, and the maintenance of all landscaping including replacing damaged or dead plant stock, trimming and litter control, garbage removal and snow removal/salting/sanding of walkways and driveways.

2.8 Signs

- 2.8.1 Ground signs shall be permitted but no ground sign shall obstruct the vision of drivers leaving/entering the roadway or driveways, or detract from the visibility or effectiveness of any traffic sign or control device on public streets. No billboards are permitted.
- 2.8.2 Signs depicting the name or corporate logo of the Developer shall be permitted while a sales office/show home is located on the site. No realtor signs shall be posted within the HRM Right of Way.

- 2.8.3 No mobile, moveable or fluorescent coloured signs or billboards shall be permitted, illuminated or otherwise.
- 2.8.4 The base of any new ground sign shall be of a material and colour which is complementary to the building.
- 2.8.5 Exterior signage for the building, including signage for the commercial uses, shall be designed to be unified, compatible and complementary to the building and shall not be located on the tower portion of the building. Illuminated signage is permitted. Fascia signage shall be limited to one sign per use and all fascia signage shall be confined to a single defined area or sign band.
- 2.8.6 Ground signs shall not exceed 4.6 metres (15 feet) in height except as a result of a specific corporate design requirement in which case the ground sign is not to exceed 7.62 metres (25 feet), No more than 2 ground signs shall be permitted on the property.
- 2.8.7 Except as otherwise specifically provided for above, all signs shall comply with the requirements of the Mainland Halifax Land Use Bylaw.

2.9 Municipal Services

- 2.9.1 All design and construction of services shall satisfy Municipal Service Systems Specifications unless otherwise provided for in this Agreement and shall receive written approval from the Development Engineer prior to undertaking the work.
- 2.9.2 Any disturbance to existing off-site infrastructure resulting from the development, including but not limited to, streets, sidewalks, curbs and gutters, street trees, landscaped areas and utilities, shall be the responsibility of the Developer, and shall be reinstated, removed, replaced and/or relocated by the Developer as directed by the Municipality's Development Officer, in consultation with the Municipality's Development Engineer.
- 2.9.3 All secondary electrical, telephone and cable service to the building shall be underground installation.
- 2.9.4 Burning of site material, such as but not limited to, vegetation, brush and trees shall be prohibited. Burning of site material may be permitted if approval in writing is granted by Fire Services.
- 2.9.5 Utility easements shall be provided as necessary but the use of easements shall be limited to locations where construction within street rights-of-way are not feasible.

- 2.9.6 The Developer is responsible for all aspects of the design, approval, construction and site improvements for the proposed intersection of the joint access driveway and the Bedford Highway, including all infrastructure associated with the semi-actuated signal lights, road realignment and the creation of a left hand turn lane as generally shown on Schedule B and included within the Addendum - Traffic Impact Study dated July 13, 2009 by Atlantic Road and Traffic Management. The intersection shall be fully operational and all associated site works complete prior to the issuance of any Occupancy Permits.
- 2.9.7 Security may be accepted by the Development Officer for the completion of outstanding on-site paving and on-site work prior to issuance of an Occupancy Permit. Such security shall consist of a security deposit in the amount of 110 per cent of a cost estimate to complete the work found acceptable to the Municipality. The security shall be in favour of the Municipality and may be in the form of a certified cheque or irrevocable, automatically renewable letter of credit issued by a chartered bank. All outstanding work shall be satisfactorily completed within one year of the date of receipt of the security deposit by the Developer. The security shall be returned to the Developer when all outstanding work is completed to the satisfaction of HRM's Development Engineer.
- 2.9.8 Prior to issuance of Building Permits, the Developer shall indicate how services will be provided to the building including, but not limited to, water supply system, sanitary sewer system, stormwater sewer and drainage systems and utilities in a method acceptable to Halifax Water, HRM's Development Engineer and any other approvals as required by any applicable agency. All costs associated with the supply and installation of all servicing systems and utilities shall be the responsibility of the Developer. All construction shall be in accordance with Municipal specifications and By-laws and HRWC Design and Construction Specifications.

2.10 Archaeological Monitoring and Protection

The lands at 50 Bedford Highway fall within the High Potential Zone for Archeological Sites identified by the Province. The Developer shall contact the Curator of Special Places with Heritage Division of the Department of Tourism, Culture and Heritage of the Province of Nova Scotia prior to any disturbance of the site and the Developer shall comply with requirements set forth by the Province in this regard as well as the requirements identified in association with Heritage Research Permit A2009NS85 and the Archaeological Desktop Study for this property by Davis Archaeological Consultants Limited, dated September 2009.

2.11 Requirements Prior to Approval

- 2.11.1 Prior to the issuance of any Municipal Permits for the building allowed by this development agreement, the Developer shall complete the MICI (Multi-unit/Industrial/Commercial/ Institutional) process, as outlined by the Municipality.

- 2.11.2 Prior to the issuance of an Occupancy Permit for the building, the Developer shall provide certification to the Development Officer from a qualified professional indicating that the Developer has complied with the Landscape Plans or provided the appropriate securities pursuant to Sections 2.6.8 and 2.6.9 of this Agreement, unless otherwise stated by the Municipality.
- 2.11.3 Prior to the issuance of an Occupancy Permit for the building, the services shall be accepted for the intersection works located at the proposed driveway access and the Bedford Highway and all associated road and site works shall be completed, accepted and fully functional as indicated in Section 2.9.6 of this agreement.
- 2.11.4 Notwithstanding any other provision of this Agreement, the Developer shall not occupy or use the Lands for any of the uses permitted by this Agreement unless an Occupancy Permit has been issued by the Municipality. No Occupancy Permit shall be issued by the Municipality unless and until the Developer has complied with all applicable provisions of this Agreement and the Land Use By-law (except to the extent that the provisions of the Land Use By-law are varied by this Agreement) and with the terms and conditions of all permits, licenses, and approvals required to be obtained by the Developer pursuant to this Agreement.

PART 3: AMENDMENTS

- 3.1 Amendments to any matters not identified under Section 3.2 of this agreement shall be deemed substantive and shall only be amended in accordance with the approval requirements of the *Halifax Regional Municipality Charter*.
- 3.2 The following items are considered by both parties to be not substantive and may be amended by resolution of Council:
- (a) Changes to the exterior architectural appearance of the building or the construction materials of the building as detailed in Section 2.4 or which, in the opinion of the Development Officer, do not conform with the attached Schedules, provided that plans are submitted for any changes to the building design;
 - (b) Changes to the landscaping measures as detailed in Section 2.6 or which, in the opinion of the Development Officer, do not conform with Schedule G;
 - (c) Changes to the amenity space size, location and/or configuration which, in the opinion of the Development Officer, do not conform with the Schedules;
 - (d) The granting of an extension to the date of commencement of construction as identified in Section 4.3 of this agreement; and
 - (e) The length of time for the completion of the development as identified in Section 4.4 of this agreement.

PART 4: REGISTRATION, EFFECT OF CONVEYANCES AND DISCHARGES

4.1 Registration

A copy of this Agreement and every amendment and/or discharge of this Agreement shall be recorded at the office of the Registry of Deeds or Land Registry Office at Halifax, Nova Scotia, and the Developer shall incur all costs in recording such documents.

4.2 Subsequent Owners

This Agreement shall be binding upon the parties thereto, their heirs, successors, assigns, mortgagees, lessees and all subsequent owners, and shall run with the Lands which are the subject of this agreement until this Agreement is discharged by Council. Upon the transfer of title, the subsequent owner(s) thereof shall observe and perform the terms and conditions of this Agreement.

4.3 Commencement of Development

- 4.3.1 In the event that development on the lands has not commenced within three (3) years from the date of registration of this Agreement at the Registry of Deeds or Land Registry Office, as indicated herein, the Agreement shall have no further force or effect and henceforth the development of the Lands shall conform to the provisions of the Land Use By-law.
- 4.3.2 For the purposes of this section, commencement shall mean completion of the footings/foundation for the proposed building or the issuance of a construction permit.
- 4.3.3 For the purposes of this section, Council may consider granting an extension of the commencement of development time period through a resolution under Section 3.2, if the Municipality receives a written request from the Developer at least sixty (60) calendar days prior to the expiration of the commencement of development time period.

4.4 Completion of Development

- 4.4.1 If the Developer fails to complete the development or portions thereof, or after five (5) years from the date of registration of this Agreement at the Registry of Deeds, whichever time period is less, Council may review this Agreement, in whole or in part, and may:
- (a) retain the Agreement in its present form;
 - (b) negotiate a new Agreement; or
 - (c) discharge this Agreement.
- 4.4.2 Upon the completion of the development or portions thereof, or within/after five (5) years from the date of registration of this Agreement with the Registry of Deeds, whichever time

period is less, Council may review this Agreement, in whole or in part, and may:

- (a) retain the Agreement in its present form;
- (b) negotiate a new Agreement;
- (c) discharge this Agreement; or
- (d) for those portions of the development which are completed, discharge this Agreement and apply appropriate zoning pursuant to the Municipal Planning Strategy and Land Use By-law for Mainland Halifax, as may be amended from time to time.

PART 5: ENFORCEMENT AND RIGHTS AND REMEDIES ON DEFAULT

- 5.1 The Developer agrees that any officer appointed by the Municipality to enforce this Agreement shall be granted access onto the Lands during all reasonable hours without obtaining consent of the Developer. The Developer further agrees that, upon receiving written notification from an officer of the Municipality to inspect the interior of any building located on the Lands, the Developer agrees to allow for such an inspection during any reasonable hour within twenty four hours of receiving such a request.
- 5.2 If the Developer fails to observe or perform any covenant or condition of this Agreement after the Municipality has given the Developer thirty (30) days written notice of the failure or default, except that such notice is waived in matters concerning environmental protection and mitigation, then in each such case:
- (a) the Municipality shall be entitled to apply to any court of competent jurisdiction for injunctive relief including an order prohibiting the Developer from continuing such default and the Developer hereby submits to the jurisdiction of such Court and waives any defense based upon the allegation that damages would be an adequate remedy;
 - (b) the Municipality may enter onto the Property and perform any of the covenants contained in this Agreement or take such remedial action as is considered necessary to correct a breach of the development agreement, whereupon all reasonable expenses whether arising out of the entry onto the Lands or from the performance of the covenants or remedial action, shall be a first lien on the Property and be shown on any tax certificate issued under the *Assessment Act*;
 - (c) the Municipality may by resolution discharge this Agreement whereupon this Agreement shall have no further force or effect and henceforth the development of the Lands shall conform with the provisions of the Land Use By-law; and/or
 - (d) in addition to the above remedies the Municipality reserves the right to pursue any other remediation under the *Halifax Regional Municipality Charter* or Common Law in order to ensure compliance with this Agreement.

WITNESS that this Agreement, made in triplicate, was properly executed by the respective Parties on this _____ day of _____, A.D., 2010.

SIGNED, SEALED AND DELIVERED)
in the presence of)

per: _____)

per: _____)

Sealed, Delivered and Attested)
by the proper signing officers of)
Halifax Regional Municipality)
duly authorized on that behalf)
in the presence of:)

_____)
per:)

BASIN VISTA DEVELOPMENTS LTD.

per: _____

per: _____

HALIFAX REGIONAL MUNICIPALITY

per: _____

MAYOR

per: _____

MUNICIPAL CLERK

DATA:
 TOTAL LOT AREA: 193,268 FT²
 LANDSCAPED AREA: 111,501 FT²
 PAVING AREA: 57,784 FT²
 BUILDING AREA: 15,986 FT²
 HOTEL: 16,459 FT²
 PARKING: 23,763 FT²
 RESIDENTIAL UNITS: 153
 HOTEL SUITES: 91

NOTE: AREAS OF BUILDING SECTIONS DIFFERS DEPENDING ON LEVEL.

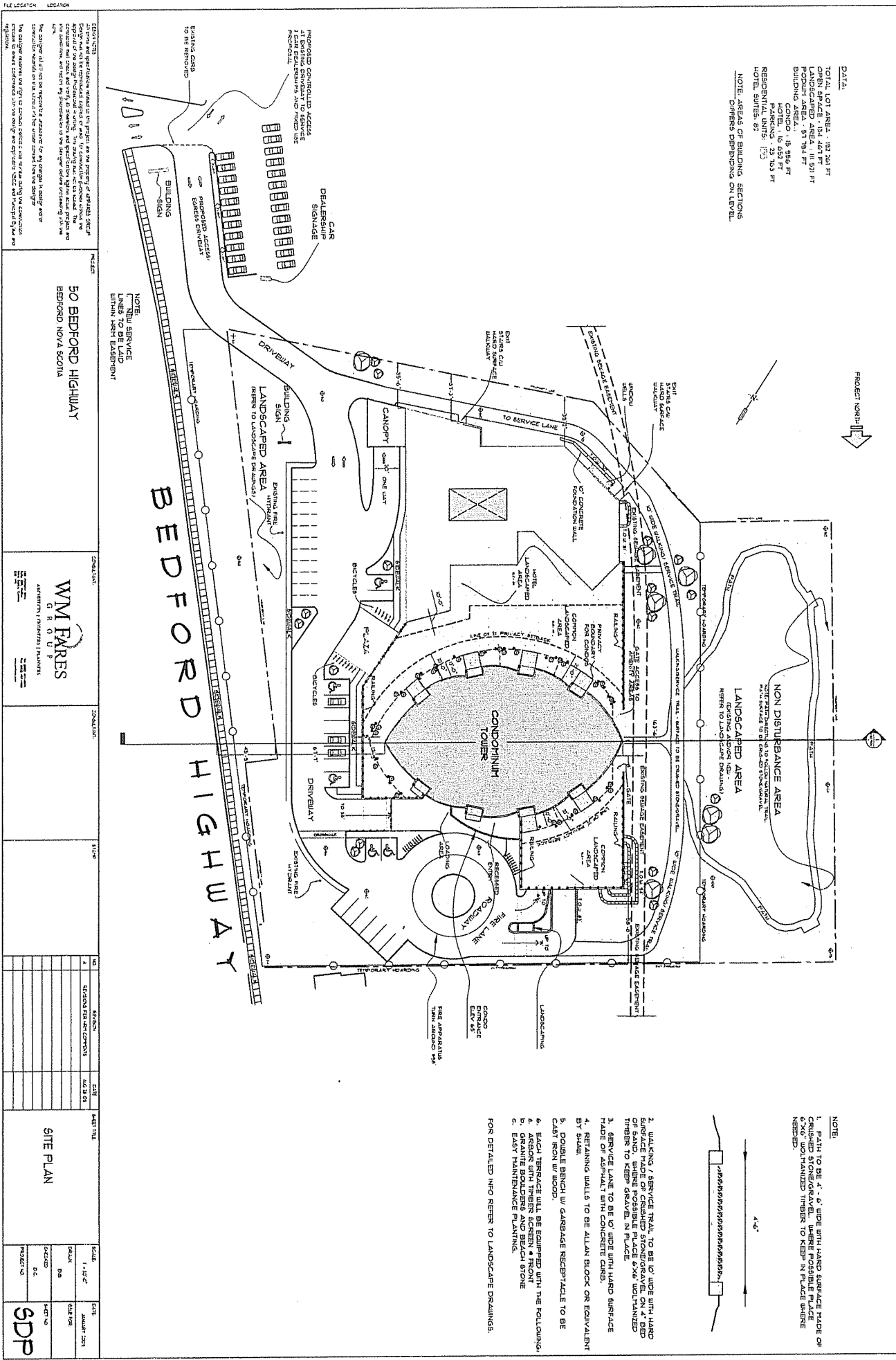

NOTE:
 1. PAVING TO BE 4" x 6" WIDE WITH HARD GARAGE MADE OF GRANITE BOLDERS AND BEACH STONE
 2. PAVING TO BE 4" x 6" WIDE WITH HARD GARAGE MADE OF GRANITE BOLDERS AND BEACH STONE
 3. PAVING TO BE 4" x 6" WIDE WITH HARD GARAGE MADE OF GRANITE BOLDERS AND BEACH STONE
 4. PAVING TO BE 4" x 6" WIDE WITH HARD GARAGE MADE OF GRANITE BOLDERS AND BEACH STONE
 5. PAVING TO BE 4" x 6" WIDE WITH HARD GARAGE MADE OF GRANITE BOLDERS AND BEACH STONE
 6. PAVING TO BE 4" x 6" WIDE WITH HARD GARAGE MADE OF GRANITE BOLDERS AND BEACH STONE
 7. PAVING TO BE 4" x 6" WIDE WITH HARD GARAGE MADE OF GRANITE BOLDERS AND BEACH STONE
 8. PAVING TO BE 4" x 6" WIDE WITH HARD GARAGE MADE OF GRANITE BOLDERS AND BEACH STONE
 9. PAVING TO BE 4" x 6" WIDE WITH HARD GARAGE MADE OF GRANITE BOLDERS AND BEACH STONE
 10. PAVING TO BE 4" x 6" WIDE WITH HARD GARAGE MADE OF GRANITE BOLDERS AND BEACH STONE

1. PAVING / SERVICE TRAIL TO BE 10' WIDE WITH HARD GARAGE MADE OF GRANITE BOLDERS AND BEACH STONE
 2. PAVING / SERVICE TRAIL TO BE 10' WIDE WITH HARD GARAGE MADE OF GRANITE BOLDERS AND BEACH STONE
 3. SERVICE LANE TO BE 10' WIDE WITH HARD SURFACE MADE OF ASPHALT WITH CONCRETE CURBS.
 4. RETAINING WALLS TO BE ALLAN BLOCK OR EQUIVALENT BY SHALL.
 5. DOUBLE BENCH W/ GARBAGE RECEPTACLE TO BE CAST IRON BY BODS.
 6. EACH TERRACE WALL BE EQUIPPED WITH THE FOLLOWING:
 - a. GRANITE BOLDERS AND BEACH STONE
 - b. EASY MAINTENANCE PLANTING.
- FOR DETAILED INFO REFER TO LANDSCAPE DRAWINGS.

<p>50 BEDFORD HIGHWAY BEDFORD NOVA SCOTIA</p>		<p>WM PARES GROUP ARCHITECTURAL CONSULTANTS</p>		<p>SCALE: 1/4" = 1'-0"</p>		<p>DATE: JANUARY 2011</p>	
<p>PROJECT: 50 BEDFORD HIGHWAY</p>		<p>SCALE: 1/4" = 1'-0"</p>		<p>DATE: JANUARY 2011</p>		<p>PROJECT: 50 BEDFORD HIGHWAY</p>	
<p>SCALE: 1/4" = 1'-0"</p>		<p>DATE: JANUARY 2011</p>		<p>PROJECT: 50 BEDFORD HIGHWAY</p>		<p>SCALE: 1/4" = 1'-0"</p>	
<p>DATE: JANUARY 2011</p>		<p>PROJECT: 50 BEDFORD HIGHWAY</p>		<p>SCALE: 1/4" = 1'-0"</p>		<p>DATE: JANUARY 2011</p>	

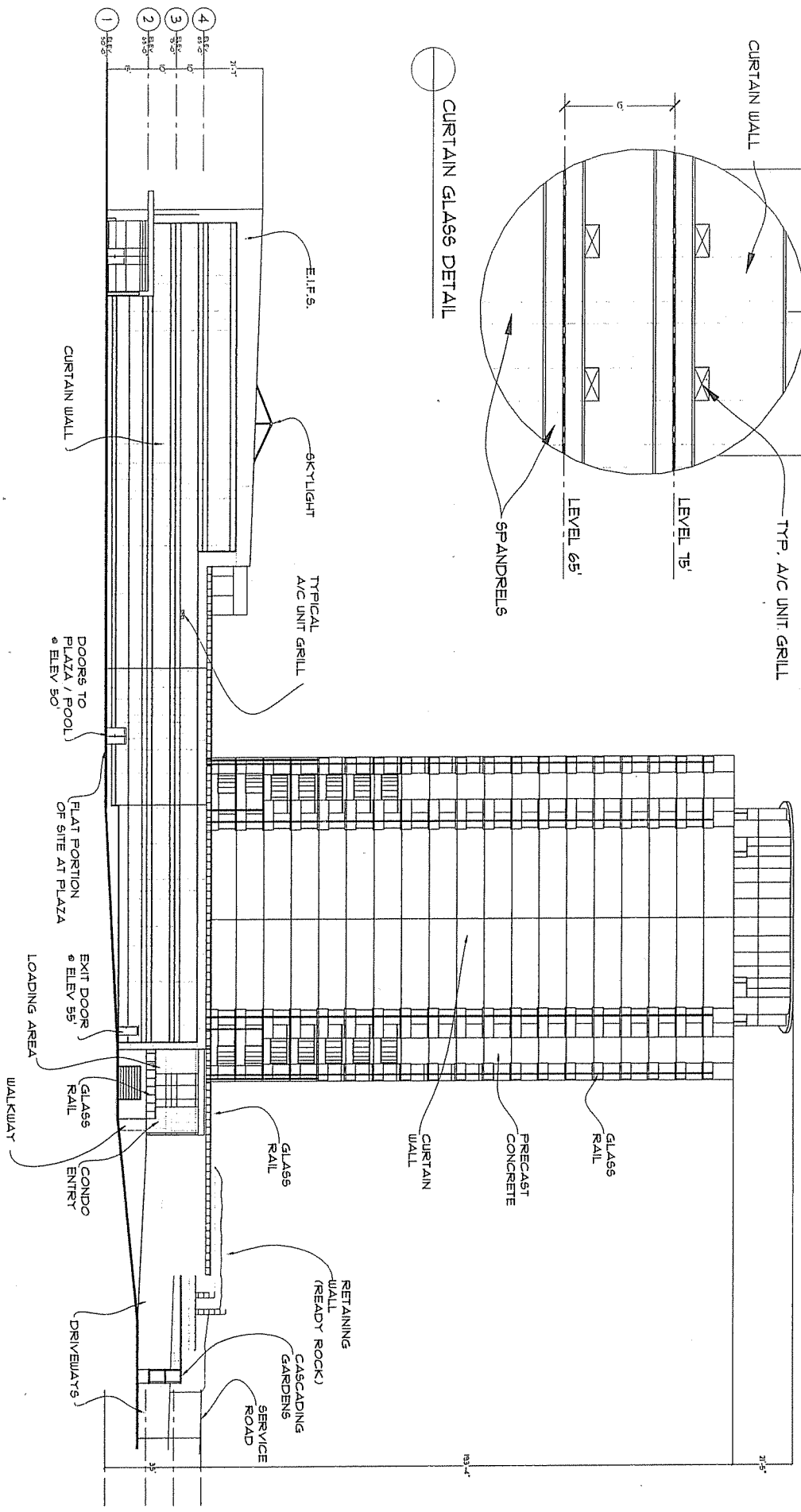
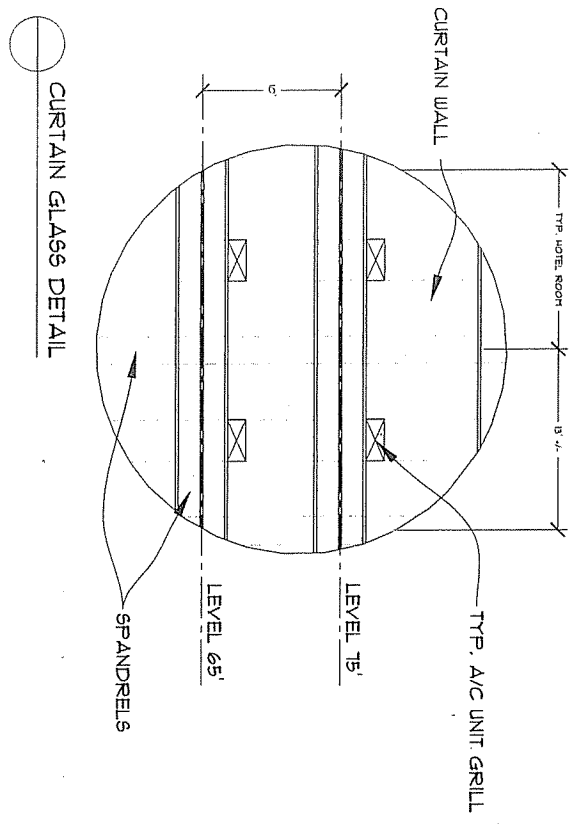

<p>NOTES:</p> <p>1. All glass and window units shall be in full compliance with the provisions of the applicable building code and shall be approved by the local authority having jurisdiction. The contractor shall verify the design of the glass and window units and shall provide the necessary details and specifications for the glass and window units. The contractor shall provide the necessary details and specifications for the glass and window units. The contractor shall provide the necessary details and specifications for the glass and window units.</p>		<p>PROJECT:</p> <p>50 BEDFORD HIGHWAY BEDFORD, NOVA SCOTIA</p>		<p>DATE:</p> <p>1/11/2024</p>		<p>SCALE:</p> <p>AS SHOWN</p>		<p>PROJECT NO.:</p> <p>100-1000</p>	
<p>CLIENT:</p> <p>WM FARES CORPORATION</p>		<p>ARCHITECT:</p> <p>W.M. FARES CORPORATION</p>		<p>DATE:</p> <p>1/11/2024</p>		<p>SCALE:</p> <p>AS SHOWN</p>		<p>PROJECT NO.:</p> <p>100-1000</p>	
<p>LOCATION:</p> <p>50 BEDFORD HIGHWAY BEDFORD, NOVA SCOTIA</p>		<p>DATE:</p> <p>1/11/2024</p>		<p>SCALE:</p> <p>AS SHOWN</p>		<p>PROJECT NO.:</p> <p>100-1000</p>		<p>PROJECT NO.:</p> <p>100-1000</p>	
<p>DATE:</p> <p>1/11/2024</p>		<p>SCALE:</p> <p>AS SHOWN</p>		<p>PROJECT NO.:</p> <p>100-1000</p>		<p>PROJECT NO.:</p> <p>100-1000</p>		<p>PROJECT NO.:</p> <p>100-1000</p>	

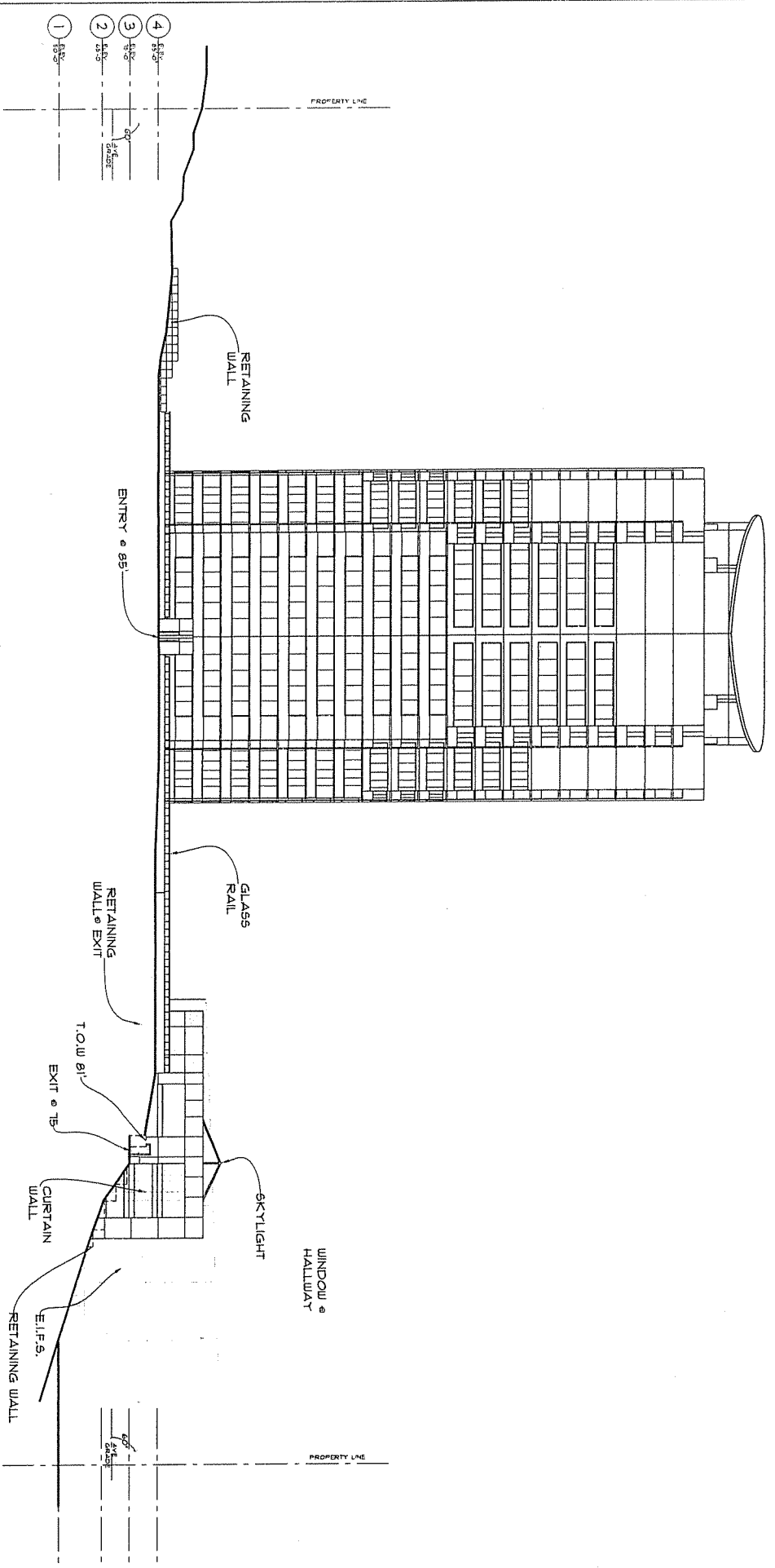

<p>DISCUSSION:</p> <p>This drawing is a preliminary elevation drawing for the proposed building. It is not intended to be used for construction purposes. The design and construction of the building shall be in accordance with the applicable codes and regulations. The design is subject to change without notice. The design is not intended to be used for construction purposes. The design is not intended to be used for construction purposes. The design is not intended to be used for construction purposes.</p>	<p>PROJECT:</p> <p>50 BEDFORD HIGHWAY BEDFORD, NOVA SCOTIA</p>	<p>CONSULTANT:</p> <p>WM FARRES ARCHITECTS INCORPORATED</p>	<p>ENGINEER:</p>	<p>DATE:</p>	<p>NO.</p>	<p>REVISION:</p>	<p>DATE:</p>	<p>WEST ELEVATION</p>	<p>SCALE:</p>	<p>DATE:</p>
					<p>1</p>	<p>2</p>	<p>3</p>		<p>4</p>	<p>1/4" = 1'-0"</p>
<p>PLAT DATE:</p>										

Schedule D, #01205-0053

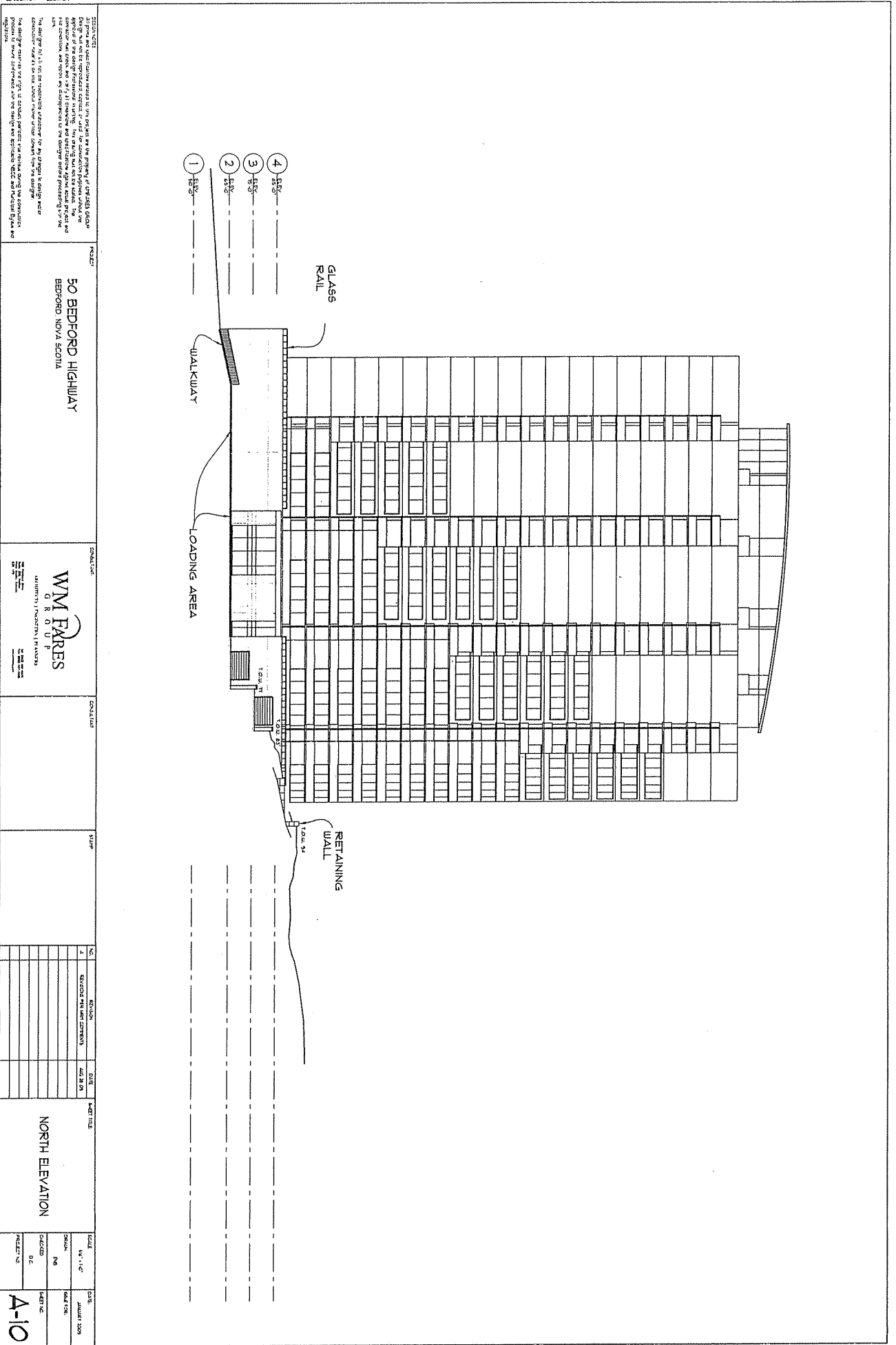

NOTICE:
 The drawings are prepared under the supervision of the professional engineer or architect who is responsible for the design and construction of the project. The drawings are prepared under the supervision of the professional engineer or architect who is responsible for the design and construction of the project. The drawings are prepared under the supervision of the professional engineer or architect who is responsible for the design and construction of the project.

PROJECT:
 50 BEDFORD HIGHWAY
 BEDFORD NOVA SCOTIA

CONSULTANT:
 W.M. FARES
 ARCHITECTS & ENGINEERS

CONTRACT NO.:
 1000-94

DATE:
 1000-94

NO.	REVISION	DATE
1		
2		
3		
4		

SCALE:
 AS SHOWN

TITLE:
 NORTH ELEVATION

DATE:
 JANUARY 2008

PROJECT NO.:
 A-10

Schedule E, #01205-0054

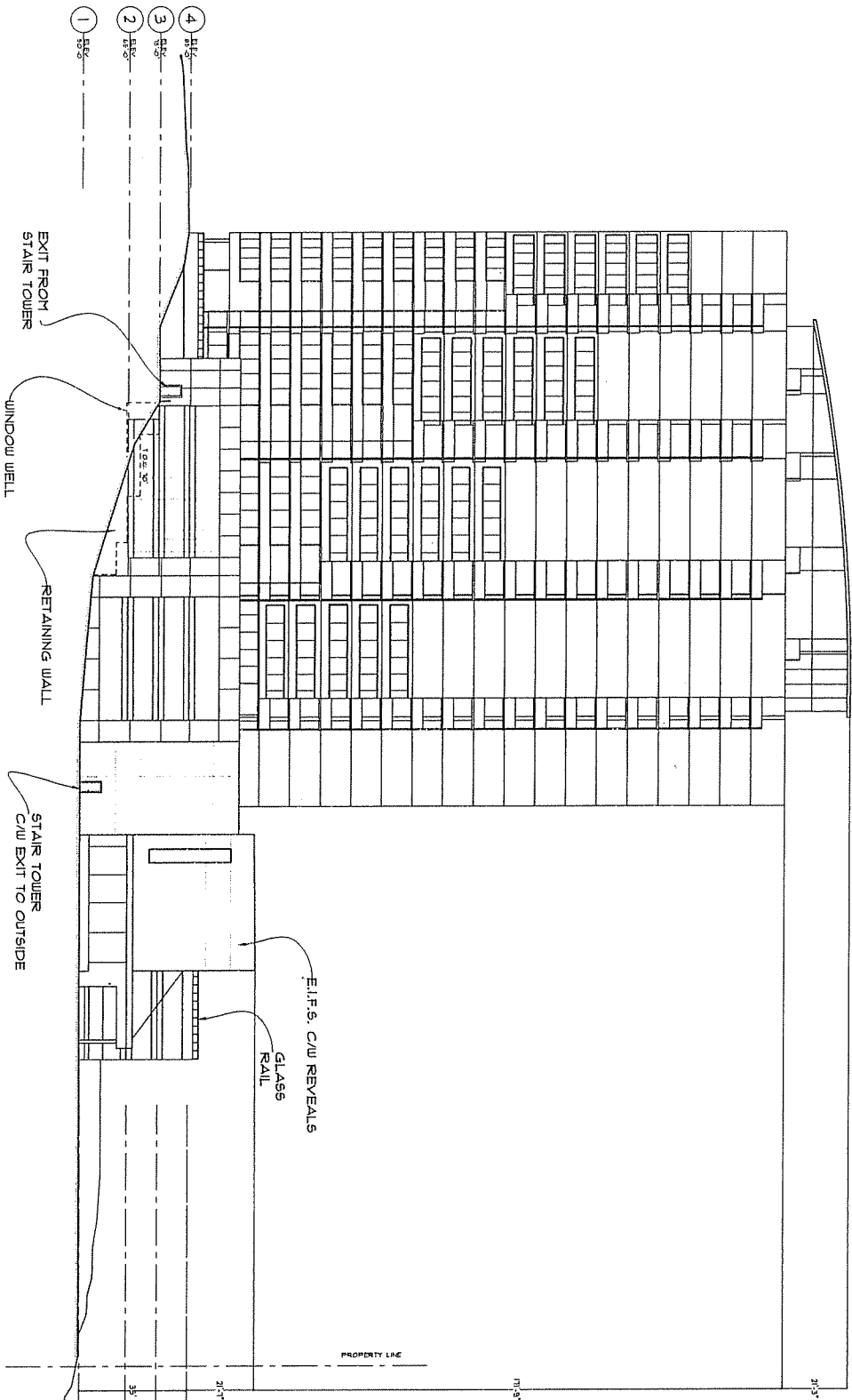

ALL RIGHTS AND RESERVATIONS ARE RESERVED BY THE ARCHITECT. NO PART OF THIS DRAWING IS TO BE REPRODUCED OR TRANSMITTED IN ANY FORM OR BY ANY MEANS, ELECTRONIC OR MECHANICAL, INCLUDING PHOTOCOPYING, RECORDING, OR BY ANY INFORMATION STORAGE AND RETRIEVAL SYSTEM, WITHOUT THE WRITTEN PERMISSION OF THE ARCHITECT. THE ARCHITECT'S LIABILITY IS LIMITED TO THE DESIGN AND CONSTRUCTION OF THE PROJECT AND DOES NOT EXTEND TO ANY OTHER MATTER. THE ARCHITECT'S LIABILITY IS LIMITED TO THE DESIGN AND CONSTRUCTION OF THE PROJECT AND DOES NOT EXTEND TO ANY OTHER MATTER. THE ARCHITECT'S LIABILITY IS LIMITED TO THE DESIGN AND CONSTRUCTION OF THE PROJECT AND DOES NOT EXTEND TO ANY OTHER MATTER.

50 BEDFORD HIGHWAY BEDFORD, NOVA SCOTIA				SOUTH ELEVATION	
NO.	DATE	BY	CHECKED	DATE	SCALE
1	10/10/10	J.S.	J.S.	10/10/10	AS SHOWN
2					
3					
4					
5					
6					
7					
8					
9					
10					
11					
12					
13					
14					
15					
16					
17					
18					
19					
20					

BYLAW CONFORMANCE CHART

Attachment C

01205 -0057

JAN. 26 2010

**PROPOSED MIXED USE BUILDING
50 BEDFORD HIGHWAY
HALIFAX, N.S.**

LAND USE BYLAW APPLICATION:			MAINLAND, R-4 ZONE		
BYLAW	DESCRIPTION	REQUIRED	PROVIDED	COMPLY	
33(1)a	MINIMUM LOT AREA REQ'D.	6,000 SQ.FT.	192 261 SQ.FT.	YES	
33(1)a	MINIMUM LOT FRONTAGE	MIN. 60.0'	500 +/- FT.	YES	
N/A	MAXIMUM LOT COVERAGE	N.A. (SEE ANGLE CONTROLS)	30%		
DENSITY CALCULATIONS:					
34(1)		LOT AREA = 192 261 SQ.FT.			
	(523.1'x30)	STREET FRONTAGE AREA = 15 693 SQ.FT.	TWO BEDROOM UNITS (155x2.25P) = 348.75 P		
		= 207 954 SQ.FT.			
		TOTAL LOT AREA = 4.77 ACRES			
		DENSITY ALLOWED: 75 P / ACRE	PROJECT DENSITY = 348.75 P	YES	
		4.77 ACRESx75P= 358 P			
BUILDING SETBACK DIMENSIONS:					
33(2)(a)(b)	FRONT (NORTH)	20.0' OR (10.0' WITHIN 80° ANGLE)	SEE SITE PLAN	YES	
33(2)(a)(b)	SOUTH	10.0'	SEE SITE PLAN	YES	
33(2)(a)(b)	EAST	10.0'	SEE SITE PLAN	YES	
33(2)(a)(b)	WEST	10.0'	SEE SITE PLAN	YES	
60° ANGLE CONTROLS:					
33(3)(a)(1)	N.W		SEE BUILDING ELEVATIONS	YES	
33(3)	N.E.		SEE BUILDING ELEVATIONS	YES	
33(3)	S.E.		SEE BUILDING ELEVATIONS	YES	
33(3)	S.W.		SEE BUILDING ELEVATIONS	YES	
BALCONY & CANOPY SETBACK DIMENSIONS:					
33(5)(a)	FRONT (SOUTH EAST)	10.0'		YES	
33(5)(a)	SOUTH WEST	10.0'		YES	
33(5)(a)	NORTH EAST	10.0'		YES	
33(5)(a)	REAR (NORTH WEST)	10.0'		YES	
33(5)(b)	CANOPY SETBACK	5.0'		YES	
LANDSCAPED OPEN SPACE:					
34(2)(b)	TWO BEDROOM UNIT (460 S.F.)	TWO BEDRM. UNITS= 155x460	TOTAL LOT AREA = 192 261 SQ.FT.		
		= 71 300 S.F.	less		
			BUILDING AREA (57 974 S.F.) =134 287 S.F.		
			PAVED AREA (37 800 S.F.) = 96 487 S.F.		
			=LANDSCAPED OPEN		
		LANDSCAPED AREA REQUIRED = 71 300 S.F.	AREA PROVIDED =96 487 S.F.	YES	
OPEN SPACE:					
34(2)(2)	TWO BEDROOM UNIT (575 S.F.)	TWO BEDRM. UNITS=155x575			
34(2)(2)		= 89 125 S.F.	LANDSCAPED AREA = 96 487 S.F.		
34(2)(2)			+ BALCONIES AREA = 11 552 S.F.		
		OPEN SPACE REQUIRED = 89 125 S.F.	= OPEN SPACE PROVIDED = 108 039 S.F.	YES	
PARKING REQUIREMENTS & RESTRICTIONS:					
9(a)(ii)	PARKING SPACES PROVIDED	HOTEL (82 ROOMS/3) = 27 SPACES	SPACES WITHIN U/G GARAGE = 243 SPACES		
		CONDO (155 UNITS) = 155 SPACES	SPACES OUTSIDE = 30 SPACES		
		TOTAL PARKING REQUIRED = 182 SPACES	TOTAL PARKING PROVIDED = 273 SPACES	YES	

ATTACHMENT D

HALIFAX REGIONAL MUNICIPALITY
PUBLIC INFORMATION MEETING

Case No. 01205: Application by W.M. Fares Group on behalf of Basin Vista Developments Limited to amend the Halifax Municipal Planning Strategy and Halifax Mainland Land Use By-law to permit a mixed use building at 50 Bedford Highway, the site of Bay View Motor Inn by development agreement.

7:00 p.m.
Thursday, April 2, 2009
Halifax West High School (Cafeteria)

STAFF IN

ATTENDANCE: Randa Wheaton, Senior Planner, HRM Planning Services
Shanan Pictou, Planning Technician, HRM Planning Services
Alana Hines, Planning Controller, HRM Planning Services

ALSO IN

ATTENDANCE: Councillor Debbie Hum, District 16
Councillor Mary Wile, District 10
Councillor Russell Walker, District 15

Applicant: Cesar Saleh, WM Fares Group

PUBLIC IN

ATTENDANCE: Approx. 25 people

The meeting commenced at approximately 7:00 p.m.

Opening Remarks/Introductions/Purpose of Meeting

Ms. Randa Wheaton welcomed everyone and introduced herself as a Senior Planner with HRM and the Planner assigned to this case. Ms. Wheaton also introduced the Councillor for the area, Councillor Hum, representing District 16, and the other Councillors present.

The agenda, purpose, and the planning process were reviewed.

Application

Ms. Wheaton described the designation and zoning for the present land uses - businesses are within the Highway Commercial Designation and Highway Commercial (C-2B) zone and residential uses are within the Environmental Designation with single and multiple unit residential zones.

Ms. Wheaton also showed a location and zoning map, which also illustrated site location.

Ms. Wheaton advised that the previous proposal was for two, 9-storey multi-unit residential buildings. The new proposal, being presented, is for a mixed use building with 150 residential units and 104 hotel suites or office space.

Ms. Wheaton highlighted the details of the proposal which included the following:

- Unique site
- DA allows some control
- Solution to traffic access
- Internal parking
- Slightly higher density
- In excess of the R-4 requirements for frontage, area, open space and landscaped open space.

Ms. Wheaton reviewed the ground rules for the meeting and passed the presentation over to the applicant, Cesar Saleh, W.M. Fares Group.

Presentation of Proposal

Mr. Saleh, welcomed everyone and gave some background on the W.M. Fares Group.

Mr. Saleh showed a site map and described the location of the proposal. He also described the following site planning and urban design considerations for this proposal:

- Site location and visibility
- Topographic features
- Interaction with the Bedford Basin
- Container ships, cranes and CN tracks
- Adjacent residential and commercial uses
- Views
- Challenging vehicular access

Project data for this proposal includes the following:

- Site area: approx. 4.5 acres
- Building area:
 - condo: 15,900 sq ft (7.8%)
 - hotel: 20,000 sq ft (10.4%)
- No. of stories: 3/19/1
- No. of hotel rooms: 104
- No residential units: 150
- 8 units per floor
- Open space: 121,344 sq ft (63%)
- Landscape: 78,000sq ft (40%)
- Number of Parking: 274/31

Mr. Saleh indicated that the proposed project is customly designed for this particular site and indicated it takes full potential of its features such as:

- 27 % site coverage
- 63 % open space
- 40 % landscape and outdoor amenity areas
- 80 foot non disturbance buffer
- 90% of parking is indoors
- The building design elements capture the essence of this site bringing visual order and making a statement.
- The building materials, glass, pre-cast concrete and composite metal, are of superior quality; they are soft in nature, yet create a visually interesting building.
- The slender and elegant tower in its unique oval shape and orientation provides for maximum views of the Bedford Basin from both, around the building and within. More importantly, it provides pleasant and interesting visuals to the Bedford Basin.
- The proposed building in its orientation and form does not pose a negative shadow impact on adjacent uses.
- The proposed project provides better and safer access to and from the Bedford Highway; it also improves the traffic flow along the Bedford Highway.

Mr. Saleh also showed a video if the proposal showing different angles and close up shots. This concluded Mr. Saleh's presentation.

Questions/Comments

Councillor Mary Wile, District 10 - Asked about driveway access. Mr. Saleh, said they are going to consolidate the access to one signalized intersection and also widening Bedford Highway to put another left hand turning lane into the dealership. Asked about entrances to the condo and hotel. Mr. Saleh said there are two separate entrances one to the condo building and the other is to the hotel and described the location using visual aid.

Marcel Hacquebord - Wanted to know if there was a commitment by the Developer to pay for the left hand turning, traffic lights, etc. Ms. Wheaton advise this would be part of the Development Agreement.

Mr. Hacquebord pointed out that the images shown in the presentation are perspective only and is very concerned about the height of the proposed building and would like to see shadow studies. He stated he has a great view presently from where he lives and is scared he will lose this view with the proposed building. He said that Mr. Saleh discussed the views and the footprint of the building which he believes will only benefit the users of the building. None of it benefits any of the surrounding people. He believes that the proposed building is going to crest the sky line and doesn't appreciate this. He is happy to hear that Mr. Saleh will pay for the driveway, but personally doesn't believe the set up will help the amount of traffic now. He thinks the previous proposal with the two eight-storey buildings would be a better proposal for this area.

Mr. Saleh indicated that there were 2 types of visuals shown. One, a 3 dimensional (3D) coloured rendering, where the focus is not on the surroundings but on the building. Thus, the relationship of the building to the surrounds would be distorted; the focus was to show an artistic rendering to show the details of the architectural design. The other visual (aerial view shots) are to scale in both elevation and footprint. There is a 90 foot elevation difference between the front and back of the building. Mr. Saleh added the footprint of the proposed building is significantly smaller than the previous proposal to allow for views around the tall building. Taller buildings cast less shadows. The did a shadow study and there are zero shadows on the residential lots above the site.

Davena Davis stated she was concerned about the traffic on the Bedford Highway because one assumes that a building with a 150 units would have one to two cars per unit and wanted to know what the plans are to control the traffic on the Bedford Highway.

Ms. Wheaton indicated that the developer is attempting to control some of the access by reducing the number of access points from what currently exists to one single access point. This will start to manage the traffic entering and leaving the site. As far as Bedford Highway itself is a whole other story, is an on-going concern and HRM's traffic people are looking at how to make improvements to this issue. Soon a new interchange will be constructed on Highway 102, which will hopefully alleviate some of the Bedford Highway traffic. Road work improvements are also being looked at for Bedford Highway, such as sidewalks, street trees, etc. Ms. Wheaton further stated that she cannot respond to how much re-configuration of Bedford Highway will happen in the near future.

Mr. Saleh added there are no traffic volume issues on the Bedford Highway when it comes to this proposal, the issues are access. The access problems are existing issues, people slowing down to enter businesses, it is difficult to make a left hand turn into the business and it is difficult to make a left hand turn coming out of the business. Mr. Saleh gave an example of testing left hand turning on a Friday at 4 pm and it was impossible and he had to take another route. As part of this proposal they are trying to start and address some of the access problems by including a controlled access point and reducing 5 access points into 1 access point.

Joanne Honeygold said she has some of the same concerns as the other speakers. The visuals showed mainly south and west and said it would have been interesting to see east and north to see how the building would impact the residential area (east and north). It would have also been interesting to see how the proposed building would impact residents at night time as it seems as it is a bright building. Ms. Honeygold agreed that there is a need for a signalized intersection. To the City, she has expressed the traffic is bad on the Bedford Highway (she stated she uses the Bedford Highway by car, cycling, walking, and the transit system) and feels that the buses won't be able to handle more people on the system. Extra is a major concern as it is, in her opinion, super dangerous.

Someone asked if a storey was considered 10 feet. Generally it is considered 10 feet.

Councillor Hum stated that Dave McCusker has been involved in studies and there will be upgrades to the Fairview overpass to address traffic issues, which is not an onus of the developer, but as a

general concern. Councillor Hum also asked that the questions raised at this meeting be addressed in the staff report. The Councillor asked what is being done about active transportation on site and if there will be trails, accessibility initiative to access other streets, trails, etc. (pedestrian access).

Glane Gorveatt indicated that one thing that bothers him about the proposal is the amount of light he sees on it. He is concerned about light pollution, due to migration of birds that fly at night, and recommended that the building be as dark as possible and that any outdoor light be reflected completely downward. He also indicated that he is worried about the extra set of lights, in the morning going into town, will make the "mess" worse. Instead could a fast lane be considered for traffic into town in the morning.

Mr. Saleh said both were good comments. In response to the first comment, through the building design process there would be measures, and through the Development Agreement there would be measures, to make sure the light reflected from the building stays on site. He pointed out that there are quite a bit of a set back between the condo building and the property lines. There is a very heavy, thick buffer of trees at the back of the site with set backs that should help with the lighting. The lighting is an engineering issue that can be dealt with so that the light is not projecting onto surrounding properties.

Leonard Farrow said there are 150 units in the building and wanted to know the approximate square footage in each of the units, unit valuation with respect to how it will affect the surrounding residential area. Mr. Farrow also stated that with respect to traffic on the Bedford Highway, he doesn't think they will resolve or add that much to it.

Mr. Saleh said that the comment on the Bedford Highway was right. The Bedford Highway is able to accept the volume. Again, they are faced it an access issue and it is this issue that they are trying to resolve. As far as the evaluation of the value of the units, he doesn't know how much they would be valued at and it is pretty early in the process to determine this. The average square footage of the condo suites is about 1400 square feet. Mr. Farrow asked what were the actual dimensions of the oval building. The widest point is 80 feet, it is oval shape and it allows for views around the building and from the building and also to present something unique and nice to look at as well.

Kathy Oakley asked how many stories higher would the condo building be compared to Stoney Brook which is 5 stories. Mr. Saleh said approximately 9 stories higher.

Aaron Shepherd asked if the plans were to maintain the same bus stop locations and asked if there would be improvements in regards to bus shelters due to the increase in population. Ms. Wheaton indicated that this application would be circulated to the transit department and they will look at it in terms of the routes and decide whether this population added at this location would allow them to shift the existing bus stops. That is something they will decide once they receive the information. They will be notified about the proposal and have an opportunity to comment on it.

Mr. Shepherd asked if it would be possible for the different views to be posted on the website. Mr. Saleh said yes, but keep in mind that there are many trees between Laurentide Drive and the proposal so standing on the edge of Laurentide and looking over there is a heavy buffer of trees between Laurentide and the Development so he's not sure how much will be shown but they will try to provide something.

Ms. Wheaton asked Mr. Saleh to provide this information to her and she could post this information to the HRM website for the public to view. Ms. Wheaton also indicated there is a lot of information on this proposal on the HRM website, under planning applications.

Glane Gorveatt said it does look like an interesting proposal. The building and use shows thought and is attractive looking.

Leonard Farrow asked who owns access and are the Dealerships on board. Mr. Saleh said that there has been communication with the Dealerships and both recognize there is an access and safety issue and they are on board.

Ms. Wheaton added that during the technical review of the application HRM will be asking the owners of those businesses to provide verification of their willingness to the joint venture of the access.

Aaron Shepherd asked about the timing of the proposal, what is the proposed start date, how long will construction take, and is there any regulation with respect to start/end times for construction.

Mr. Saleh said there are regulations that dictate when construction can take place in the land use bylaw. As far as the process itself, they hope to get through the process within 6 to 8 months and construction would take approximately 18 months to 2 years.

Closing Comments

With no more questions/comments, Ms. Wheaton thanked everyone for coming and advised that the minutes will be attached to the staff report going to Community Council. Notification will go out when the Public Hearing date is set.

Adjournment

The meeting adjourned at approximately 8:10 p.m.